

# For Lease

Boutique Corner  
Retail Opportunity

**398** Spadina  
Avenue



METROPOLITAN  
COMMERCIAL



# Offering Summary

---

New fully-renovated corner retail property, **398 Spadina Avenue** is ideally situated in the heart of Chinatown-Kensington.

- Excellent frontage and visibility
- Very high pedestrian & vehicular traffic
  - Fully renovated
- Brand new HVAC & storefront
- Potential for Patio/Parking
- Ideal for a variety of uses

## Property Details

---

<b>Unit Size</b>	572 SF & 806 SF
------------------	-----------------

---

<b>Net Rent</b>	Please contact
-----------------	----------------

---

<b>TMI</b>	\$36.00
------------	---------

---

<b>Available</b>	Immediately
------------------	-------------



# 398 Spadina Ave - Floor Plan

---

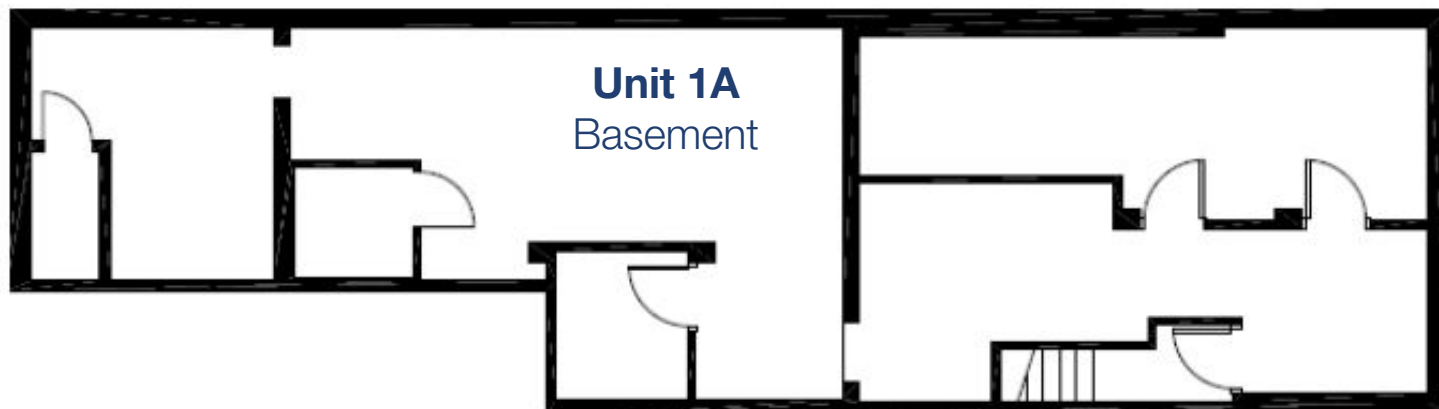
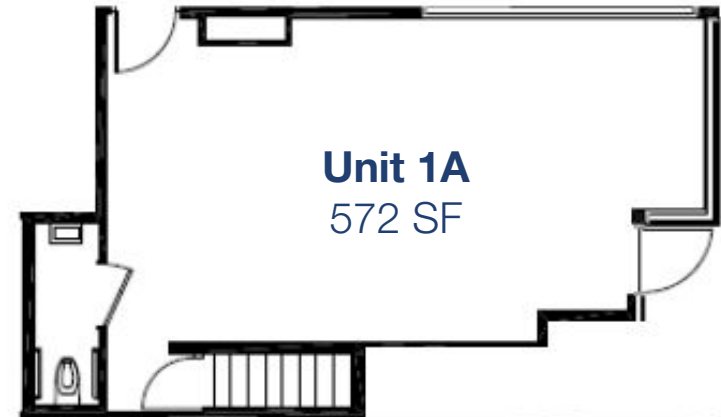
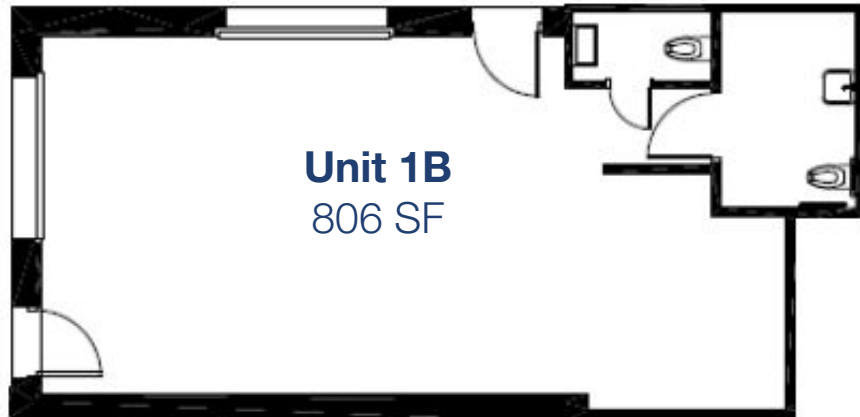





# 398 Spadina Ave - Neighbourhood Overview



Chinatown is a standout location of culture and experience in Toronto, being the second largest in the entirety of North America second only to New York. It is known for its shops and restaurants that are rich in Asian tradition, showcasing a mixture of old neighbourhood staples and new venues that pay tribute to the area. The streets are filled with pedestrians, aided by the frequent streetcars heading to and from the Spadina TTC station.

The University of Toronto is one of the world's most elite Universities. Its downtown campus is located just North East of 398 Spadina Ave. The downtown campus alone has a student population of 61,690 individuals that heavily contributing to Spadina Avenue's busy pedestrian population.

Kensington Market is known as the most vibrant and diverse neighbourhood in Toronto, making it a popular destination for both tourists and locals. This area is heavy in pedestrian traffic which makes it the perfect location for its array of unique shops and restaurants, live music, street performances, and art installments.

El Mocambo is an example of a neighbourhood staple located 464 Spadina Avenue that gives the area the rich culture it is known for. It is a live music venue that has been open since 1948 and has hosted a number of legends such as the Rolling Stones, Blondie, Jimi Hendrix, Meatloaf, U2, etc.



# NEIGHBOURING DEVELOPMENT



## 315 SPADINA: PODIUM DEVELOPMENTS

**315 Spadina Avenue Apartments** is a new development by Podium Developments currently in pre-construction at Spadina Avenue & D'Arcy Street.

The developer has submitted a rezoning application that proposes a 13-storey mixed-use building with a total gross floor area of 15,892 square metres and a density of 7.83 times the area of the lot. The ground floor will contain 988 square metres of retail space. A total of 239 rental residential units are proposed within the 12 floors above the ground floor. The unit mix is comprised of 172 studio units, 11 one-bedroom units, 31 two-bedroom units and 25 three-bedroom units.



# 398 Spadina Ave - Transit Connectivity







**METROPOLITAN**  
COMMERCIAL

**Ming Zee**

President, Broker of Record

416.703.6621 x 222

ming.zee@metcomrealty.com

**Kevin Tuttle**

Broker

416.703.6621 x 227

kevin.tuttle@metcomrealty.com

**Nick Nankissoor**

Sales Representative

416.703.6621 x 241

nick@metcomrealty.com

**Metropolitan Commercial Realty Inc.**

150 Beverley Street, Unit 1

Toronto, ON M5T 1Y5

**[metcomrealty.com](http://metcomrealty.com)**

Disclaimer: The information contained herein has been provided to Metropolitan Commercial Realty Inc. from sources deemed reliable and correct, however we do not warrant its accuracy or assume any responsibility or liability of any kind whatsoever with respect to the accuracy of the information contained herein. All persons are advised to independently verify the information. The information herein is subject to errors, omissions, change of price, rental or other conditions, prior sale or withdrawal at any time without notice. Metropolitan Commercial Realty Inc., Brokerage. \*Sales Representative